

HSF

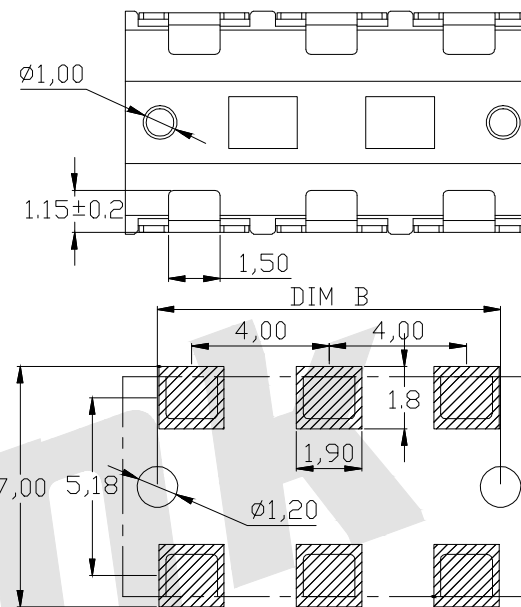

RECOMMENDED PCB LAYOUT
TOP VIEW (. XX±0.05)

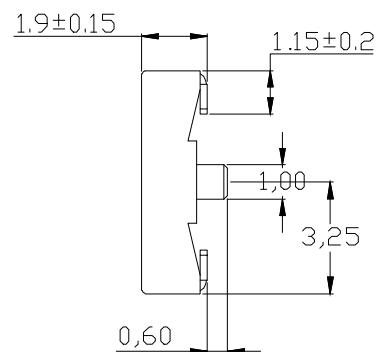
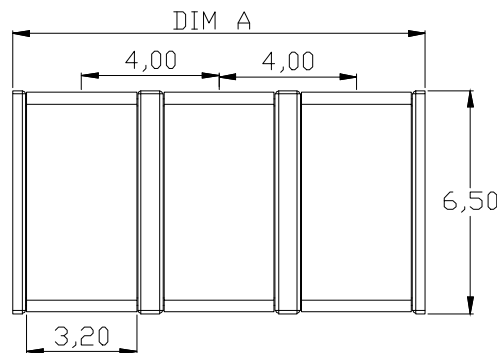
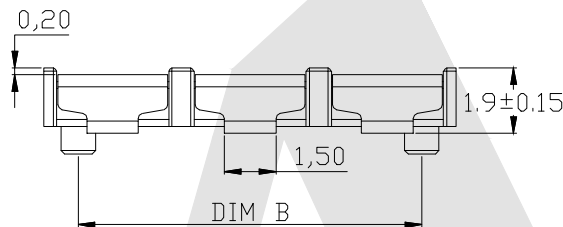

SPECIFICATIONS:

1. VOLTAGE RATING:30 V
2. CURRENT RATING:5.0 A
3. WITHSTAND VOLTAGE:500 V
4. INSULATION RESISTANCE:500 MEG OHM MIN
5. CONTACT RESISTANCE:30 MILL. OHM MAX
6. OPERATION TEMPERATURE:-55° C TO +125° C
7. PLASTIC MATERIAL:LCP BLACK
8. CONTACT POINT MATERIAL:BRASS C2680, GOLD PLATING
9. LIFE TEST:10000 TIMES MIN

Ordering Code:

ABT32 - 03 - L - D - X - D

① ② ③ ④ ⑤ ⑥

- | | |
|-----------------------|--------------------|
| ① Series No: | ⑤ Contact Plating: |
| ② No. of Contacts | G0:Gold flash |
| 03:03Pin | G1:3u" gold |
| ③ Insulator Material: | G2: 5u" gold |
| P:PBT+30%GF | G3:10u" gold |
| L:LCP 9:PA9T | G4:15u" gold |
| ④ Pitch | G5:30u" gold |
| D:4.0mm Pitch | ⑥ Packing: |
| | A:Tray |
| | B:Bag |
| | C:Tube |
| | D:Tape Reel |

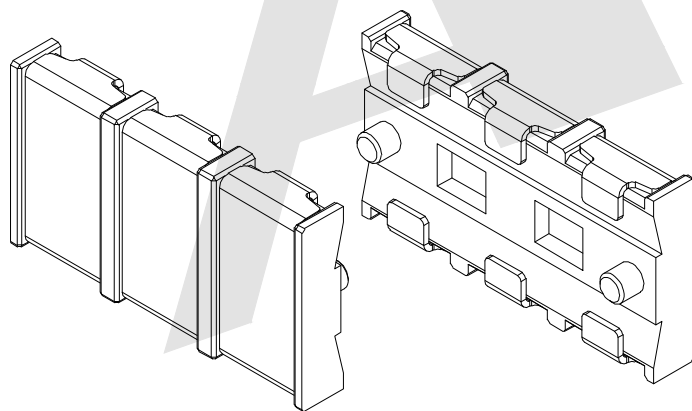

PIN	PART NO.	DIM A	DIM B
2P	ABT32-029DXD	8.0	6.0
3P	ABT32-039DXD	12.0	10.0
4P	ABT32-049DXD	16.0	14.0
5P	ABT32-059DXD	20.0	18.0
6P	ABT32-069DXD	24.0	22.0

Unless Otherwise specified tolerance
X. ±0.35 X.XX:±0.20
X.X:±0.25 X.XXX:±0.15

SCALE: As Shown	UNIT: mm
DRAW Wu Feng Rong	DATE 22/07/2020
CHECK BobYang	DATE 22/07/2020



Antenk® ANTENK ELECTRONICS CO.,LTD
Http://www.antenk.com
E-mail:sales@antenk.com

TITLE:
4.0 PITCH 3PIN BATTERY FEMALE CONNECTOR

DRAWING NO: ABT32-03LDXD
PRODUCT NO: ABT32-03LDXD

REV	DESCRIPTION	DATE