

技术参数表 / Technical parameter

A: 全排量 First displacement B: 半排量 Second displacement

型号 Type	排量代号 Displacement Code	A (ml/r)	B (ml/r)	A		额定压力 Rated Pressure (Mpa)	最高压力 Max Pressure (Mpa)	转速范围 Speed Range (r/min)	最大功率 Max Power		
				额定扭矩 Rated Torque (N.m)	理论扭矩 Theoretical Torque (10Mpa N.m)				A (kW)	优先旋向 Preferred (kW)	非优先旋向 Non-preferred (kW)
YMS83	8	6679	3340	26550	10620	25	35	0-65	220	135	70
	0	8328	4164	33105	13242	25	35	0-52			
	2	10019	5010	39825	15930	25	35	0-43			

马达编号 / Motor model code

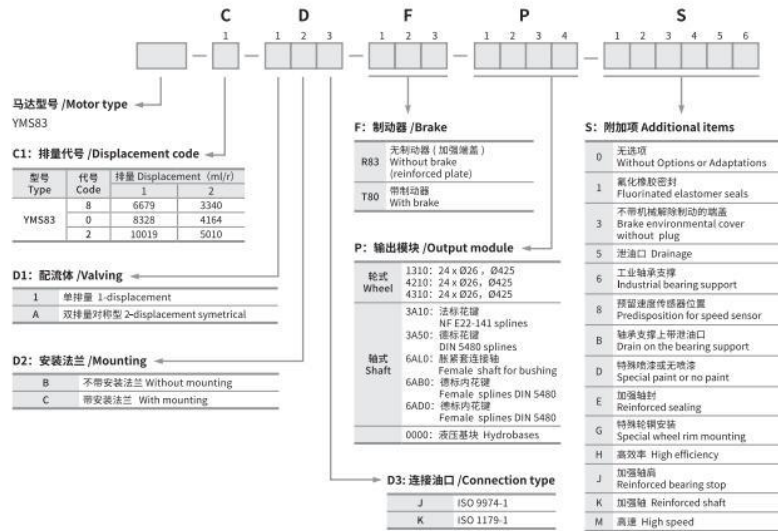

轮边马达 / Wheel motor

双排量马达标准尺寸 / Dimensions for 2-displacement motor

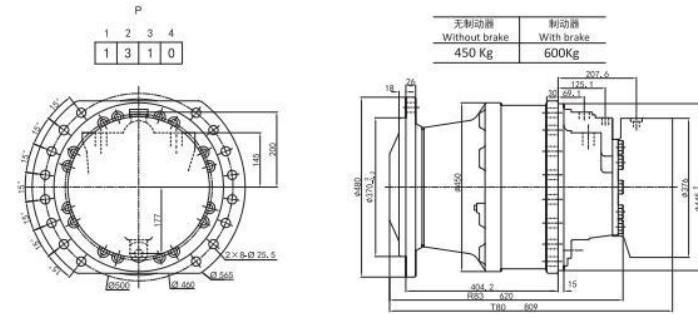

轴承支撑类型 / Support types

输出方式 Output Type	A (mm)	B (mm)	C (mm)	D (mm)	E (mm)	N (mm)	轮辋配件 Wheel Rim Mountings	L (mm)	标注图 Figure
1310	Ø370	Ø425	Ø470	404.2	Ø444	Ø26	24×M24×2	24	
4210	Ø370	Ø425	Ø470	284.5	Ø444	Ø26	24×M24×2	25	
4310	Ø370	Ø425	Ø470	239	Ø444	Ø26	24×M24×2	24	

轴马达 / Shaft motor

双排量马达标准尺寸 / Dimensions for 2-displacement motor

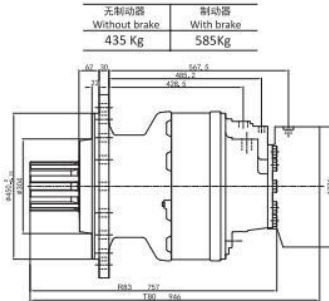
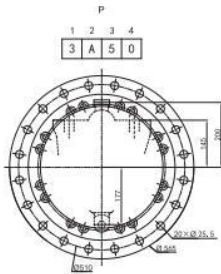

轴承支撑类型 / Support types

输出方式 Output Type	规格 Specification	A (mm)	B (mm)	C (mm)	D (mm)	E (mm)	F (mm)	G (mm)	标注图 Figure
3A10	法标花键 NF E22-141 splines	40	R4	60	2×M16	31	150	-	
	公称直径 ØNominalØ 150								
	模数 Module 3.75								
3A50	德标花键 DIN 5480 splines	40	R4	60	2×M16	32	150	-	
	公称直径 ØNominalØ 150								
	模数 Module 5								
6A10	德标花键 DIN 5480 splines	Ø140	Ø185	230	426	Ø340	Ø380	16×M20	
	公称直径 ØNominalØ 150								
	模数 Module 5								
6A80	德标花键 DIN 5480 splines	Ø142	Ø199	190	432	Ø340	Ø380	16×M20	
	公称直径 ØNominalØ 150								
	模数 Module 5								
6A20	德标花键 DIN 5480 splines	Ø142	Ø199	190	438	Ø340	Ø380	16×M20	
	公称直径 ØNominalØ 150								
	模数 Module 5								

双排量液压基块标准尺寸 / Dimensions for 2-displacement hydrobase

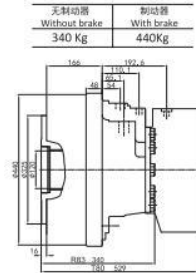
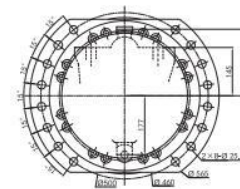

液压连接油口 / Hydraulic Connections

编号 Code	标准 Standards	主油口 (A, B) Power supply	壳体泄油口 (L) Case drain	驻车制动控制油口 (Z) Control of parking brake	双排量油口 2-displacement control
J	ISO 9974-1		M27x2	M18*1.5	M18*1.5
K	ISO 1179-1	DN32 PN400	Ø27	Ø17	Ø17

制动器原理 / Brake principle

T 8 0

制动腔内压力为 0 时制动器的制动扭矩 (新制动器) Parking brake torque at 0 bars on housing (new brake)	72000N.m
制动腔内压力为 0 时紧急行车制动扭矩 (最多可作紧急制动使用 10 次) Dynamic emergency braking torque at 0 bars on housing (max.10 uses of emergency brakes)	62400N.m
制动腔内压力为 0 时剩余的驻车制动扭矩 Residual parking braking at 0 bars on housing	54000N.m
最小制动器释放压力 Min. brake release pressure	2Mpa
最大制动器释放压力 Max. brake release pressure	3Mpa
制动腔油量 Oil capacity	450ml
用于制动器释放的液压油量 Volume for brake release	135ml